



# M15

## Plate Heat Exchanger

### Applications

General heating and cooling duties.

### Standard design

The plate heat exchanger consists of a pack of corrugated metal plates with portholes for the passage of the two fluids between which heat transfer will take place.

The plate pack is assembled between a fix frame plate and a movable pressure plate and compressed by tightening bolts. The plates are fitted with a gasket which seals the interplate channel and directs the fluids into alternate channels. The number of plates is determined by the flow rate, physical properties of the fluids, pressure drop and temperature program. The plate corrugations promote fluid turbulence and support the plates against differential pressure.

The plate and the pressure plate are suspended from an upper carrying bar and located by a lower guiding bar, both of which are fixed to a support column.

Connections are located in the frame plate or, if either or both fluids make more than a single pass within the unit, in the frame and pressure plates.

### Typical capacities

#### Liquid flow rate

Up to 80 kg/s (1300 gpm), depending on media, permitted pressure drop and temperature program.

### Plate Types

M15-B, M15-M and M15-BD, double wall plates

### Frame types

FL, FM, FG and FD

### Working principle

Channels are formed between the plates and the corner ports are arranged so that the two media flow through alternate channels. The heat is transferred through the plate between the channels, and complete counter-current flow is created for highest possible efficiency. The corrugation of the plates provides the passage between the plates, supports each plate against the adjacent one and enhances the turbulence, resulting in efficient heat transfer.



M15-BFM

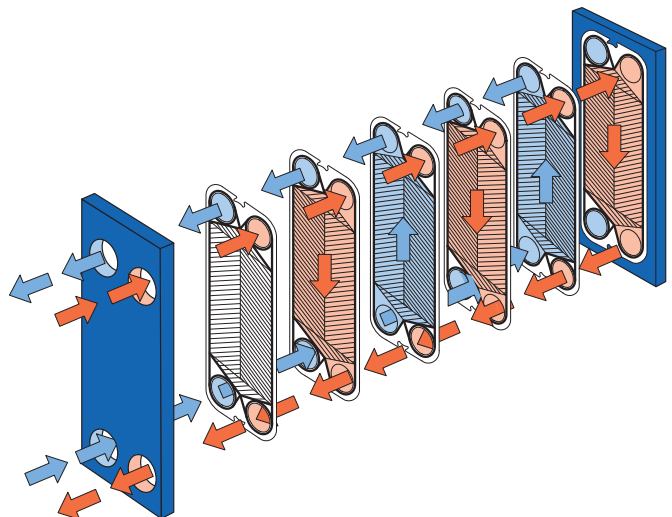

Flow principle of a plate heat exchanger

## STANDARD MATERIALS

### Frame plate

Mild steel, Epoxy painted

### Nozzles

Carbon steel

Metal lined: Stainless steel, Titanium

Rubber lined: Nitrile, EPDM

### Plates

Stainless steel: Alloy 304, Alloy 316, Alloy C276, Alloy 254 SMO, Titanium

### Gaskets (Clip-on/tape-on, glued)

Nitrile, EPDM, Viton®

Other grades and material available on request.

## TECHNICAL DATA

### Pressure vessel codes, PED, ASME, pvcALS™

#### Mechanical design pressure (g) / temperature

FL	pvcALS™	0.6 MPa / 130°C
FM	PED, pvcALS™	1.0 MPa / 180°C
FG	PED, pvcALS™	1.6 MPa / 180°C
FG	ASME	170 psig / 482°F
FD	PED, pvcALS™	3.0 MPa / 180°C
FD	ASME	300 psig / 356°F

### Connections

		Size:	
FL	pvcALS™	150 mm	DIN/GB/GOST PN10, JIS 10K
FM	PED	150 mm	DIN PN10, ASME Cl. 150
FM	pvcALS™	150 mm	DIN/GB/GOST PN10, ASME Cl. 150, JIS 10K
FG	PED	150 mm	DIN PN16, ASME Cl. 150
FG	pvcALS™	150 mm	DIN/GB/GOST PN16, ASME Cl. 150, JIS 10K, JIS 16K
FG	ASME	6"	ASME Cl. 150
FD	PED	150 mm	DIN PN25, ASME Cl. 300
FD	ASME	6"	ASME Cl. 300

### Maximum heat transfer surface

390 m<sup>2</sup> (4200 sq. ft)

## Dimensions

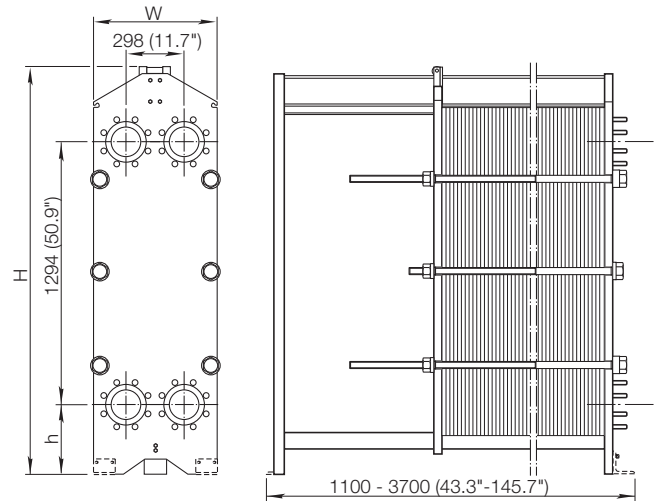

### Measurements mm (inch)

Type	H	W	h
M15-FL	1815 (71.5")	610 (24")	275 (10.8")
M15-FM	max. 1941 (76.4")	610 (24")	275 (10.8")
M15-FG	max. 1941 (76.4")	650 (25.6")	275 (10.8")
M15-FD	max. 2036 (80.2")	650 (25.6")	370 (14.6")

The number of tightening bolts may vary depending on pressure rating.

### Particulars required for quotation

- Flow rates or heat load
- Temperature program
- Physical properties of liquids in question (if not water)
- Desired working pressure
- Maximum permitted pressure drop
- Available steam pressure

### How to contact Alfa Laval

Up-to-date AlfaLaval contact details for all countries are always available on our website on [www.alfalaval.com](http://www.alfalaval.com)