



Dryplus-E shell & tube evaporators

A new series of R134a dry-expansion evaporators, optimized for large-scale air conditioning and refrigeration





The power of evolution

The parent generation of the Dryplus-E series provided an example of frontline technology within air conditioning and cooling. With the next generation, performance has been taken one step further. The Dryplus-E evaporators bring solid testimony to the power – and measurable value – of technological evolution.

Thanks to their innovative design, the Dryplus-E evaporators ensure high efficiency, even at partial loads. They meet demands for cooling capacity up to 1420 kW (4845 kBtu/h) at nominal conditions* and will serve 1 to 4 separate cooling circuits. A new optimized baffle configuration ensures a diagonal water flow and 3 different positions for water connections. The ingenious design of the exchange tube provides increased cooling capacity. For maximum performance, the Dryplus-E evaporators were designed specifically for operation with R134a refrigerant.

Raising evaporation temperatures, a fundamental parameter for cooling efficiency, indicates the improvement of performance brought by the Dryplus-E evaporators.

chiller units (>300 kW / 1020 kBtu/h) operating continuously during the whole year – e.g. in process industries or comfort applications. This generates a demand for chillers and heat exchangers operating at modest running costs – both at full capacity and partial load.

Thanks to the high evaporation temperature and reduced approach offered by the Dryplus-E evaporators, the COP (Coefficient Of Performance) can be raised by an average 28 percent in comparison with an equivalent R407C or R22 system, as depicted in Figure 1.

*Nominal conditions – Refrigerant R134a:
 Water inlet/outlet temperature 12/7°C (53.6/44.6°F)
 Evaporation temperature 3°C (37.4°F)
 Condensing temperature 38°C (100.4°F)
 Superheating 5K (9°F)
 Subcooling 3K (5.4°F)
 Lubricant oil ISO68
 Shell-side fouling factor 0.000043 m².K/W (0.00024 ft².h.°F/Btu).



On the road to Kyoto

The Dryplus-E series was developed to meet articulate market demands for cooling systems offering a combination of high efficiency and Kyoto protocol compliance. During the last few years, mounting environmental concerns and increased cost-efficiency awareness have accentuated this demand profile.

When it comes to high-performance units, the typical requirement specification often implies medium capacity

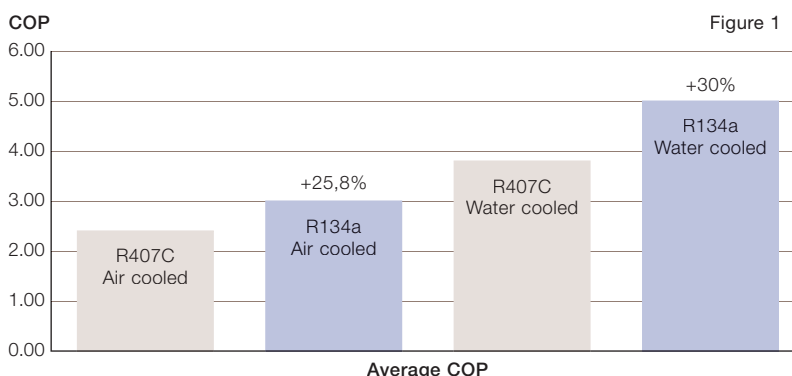

Perfection expressed as design

- Evaporators optimized for R134a and high efficiency duties
- Reduced refrigerant charge
- Low pressure drop design
- Advanced finned copper tubes
- Flanged refrigerant connections



R134a shell & tube condensers

In water-cooled chillers, the evaporator is an important performance factor. Still, total performance is heavily influenced also by the performance properties of the condenser. By reducing the approach value between the condensing temperature and the temperature of the water outlet, thermal efficiency can be increased drastically. For this reason, Alfa Laval offers a complete range of shell and tube condensers for R134a chillers. CDEW is a comprehensive range of condensers with capacities up to 1700 kW (5800 kBtu/h) while CDEW-E is a series optimized for R134a chillers with relatively low approach values.

The Dryplus-E range is a result of research targeted to ensure a high level of mechanical strength and high resistance to vibrations and corrosion. The U-shaped design of the tube bundle allows thermal expansion between the tubes and the shell without any mechanical strain, and the tube bundle can be extracted from the shell for service. When needed to change the water connection position, the shell can also be rotated.

The selection of materials has been made to optimize the heat exchange parameters and to ensure the interaction of functions. The specification of materials for the Dryplus-E series reflects a scientific approach, vast volumes of performance analysis and many years of practical experience.

- Header, tube sheet, shell and connections for refrigerants and water are made of carbon steel

- Copper exchange tubes, finned on the inside for higher performance
- Brass or carbon steel baffles
- The bolt system is made of steel alloys or stainless steel – depending on function and temperature. Gaskets are made of long-life materials.

The evaporators are available with vital components in stainless steel – i.e. tube sheet, exchange tubes and shell. Versions with carbon steel or CuNi tubes available.

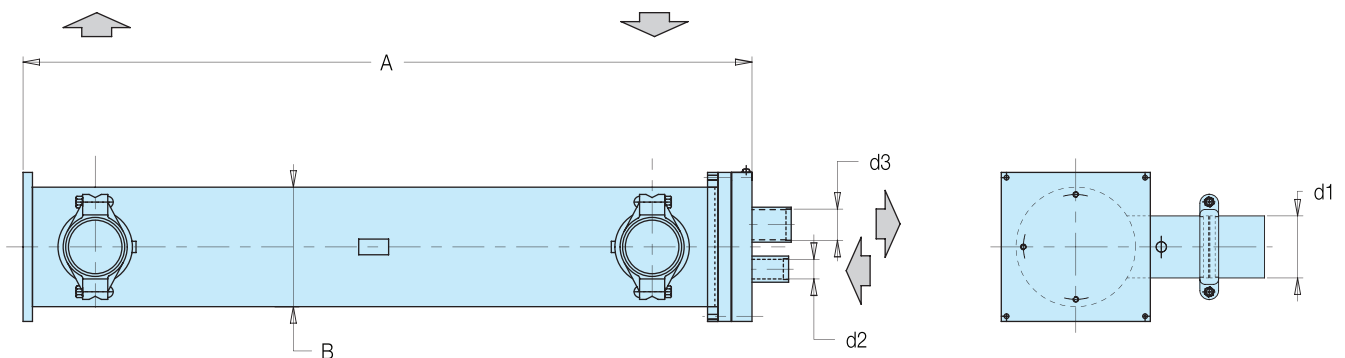

Nominal Conditions		Refrigerant: R134a	$T_{\text{brine IN}} = 12^{\circ}\text{C}$ (53.60°F)	$T_{\text{brine OUT}} = 7^{\circ}\text{C}$ (44.60°F)	$T_{\text{cond}} = 38^{\circ}\text{C}$ (100.4°F)	$T_{\text{ev}} = 3^{\circ}\text{C}$ (37.40°F)	$\Delta T_{\text{sc}} = 3 \text{ K}$ (5.40°F)	$\Delta T_{\text{sh}} = 5 \text{ K}$ (9°F)	Lubricant oil ISO68
Model	N° of circuits	Q_{Nom} kW (kBtu/h)	Δp_{Nom} kPa (Psi)	A mm (inch)	B mm (inch)	d1	d2	d3	
DES	130	1	131 (447)	46 (6.67)	2316 (91" 3/16)	219 (8" 1/2)	J3	FA-42	FB-67
DED		2						RC-35	FA-54
DET		3						2296 (90" 3/8)	WA 22
DES	175	1	178 (607)	30 (4.35)	2368 (93" 7/32)	273 (10" 3/4)	J4	FA-42	FC-80
DED		2						FA-35	FB-67
DET		3						2347 (92" 13/32)	WA 35
DES	240	1	238 (812)	46 (6.67)	2648 (104" 1/4)	273 (10" 3/4)	J4	FA-42	FC-80
DED		2						FA-35	FB-67
DET		3						2627 (103" 7/16)	WA 35
DES	265	1	265 (904)	29 (4.21)	2698 (106" 7/32)	324 (12" 3/4)	J5	FA-42	SAE ST-114
DED		2						FA-35	FC-80
DET		3						2677 (105" 13/32)	FA-35
DES	315	1	314 (1071)	37 (5.37)	2698 (106" 7/32)	324 (12" 3/4)	J5	FA-42	SAE ST-114
DED		2						FA-35	FC-80
DET		3						2677 (105" 13/32)	FA-35
DES	350	1	352 (1201)	40 (5.80)	2698 (106" 7/32)	324 (12" 3/4)	J5	FA-42	SAE ST-114
DED		2						FA-35	FC-80
DET		3						2677 (105" 13/32)	FA-35
DED	440	2	439 (1498)	29 (4.21)	2741 (107" 29/32)	406 (16")	J6	FA-42	SAE ST-114
DET		3			2717 (106" 31/32)			FA-35	FC-80
DEQ		4			FA-35			FB-67	
DED	535	2	535 (1825)	36.3 (5.26)	2741 (107" 29/32)	406 (16")	J6	FA-42	SAE ST-114
DET		3			2717 (106" 31/32)			FA-35	FC-80
DEQ		4			FA-35			FB-67	
DED	585	2	587 (2003)	50 (7.25)	3241 (127" 19/32)	406 (16")	J6	FA-42	SAE ST-114
DET		3			3217 (126" 21/32)			FA-35	FC-80
DEQ		4			FA-35			FB-67	
DED	645	2	644 (2200)	24 (3.48)	2778 (109" 3/8)	457 (18")	J8	FA-42	SAE ST-114
DET		3			2762 (108" 3/4)			FA-42	FC-80
DEQ		4			FA-35			FC-80	
DED	715	2	715 (2440)	33.4 (4.84)	3278 (129" 1/16)	457 (18")	J8	FA-42	SAE ST-114
DET		3			3262 (128" 7/16)			FA-42	FC-80
DEQ		4			FA-35			FC-80	
DED	745	2	743 (2535)	33 (4.79)	3803 (149" 23/32)	508 (20")	J8	FB-54	SAE ST-114
DET		3			3787 (149" 3/32)			FA-42	SAE ST-114
DEQ		4			FA-42			FC-80	
DED	860	2	860 (2934)	51 (7.40)	3803 (149" 23/32)	508 (20")	J8	FB-54	SAE ST-114
DET		3			3787 (149" 3/32)			FA-42	SAE ST-114
DEQ		4			FA-42			FC-80	
DED	955	2	955 (3258)	66.2 (9.60)	3803 (149" 23/32)	508 (20")	J8	FB-54	SAE ST-114
DET		3			3787 (149" 3/32)			FA-42	SAE ST-114
DEQ		4			FA-42			FC-80	
DED	1100	2	1100 (3753)	43.8 (6.35)	3342 (131" 9/16)	559 (22")	J8/10	FB-67	SAE ST-140
DET		3						FB-54	SAE ST-114
DEQ		4						FA-42	FC-80
DED	1220	2	1220 (4163)	64.2 (9.31)	3842 (151" 1/4)	559 (22")	J8/10	FB-67	SAE ST-140
DET		3						FB-54	SAE ST-114
DEQ		4						FA-42	FC-80
DET	1290	3	1290 (4402)	50 (7.25)	3352 (131" 31/32)	610 (24")	J8/10	FB-54	SAE ST-140
DEQ		4						FA-42	FC-80
DET	1420	3	1420 (4845)	72.4 (10.5)	3852 (131" 21/32)	610 (24")	J8/10	FB-54	SAE ST-140
DEQ		4						FA-42	FC-80



Performance and features



- Optimized for R134a high-efficiency duties – 4.5-5 COP – in water-cooled chillers
- Designed to match screw or turbo R134a compressors
- Meets high efficiency demands as well as severe environmental standards
- Tubes ensure safe oil return, even for the most viscous oils
- Excellent partial load performance
- Compact measures – maximum length < 4 m (13 ft)
- Extractable tube bundle
- Integrated square support version avoiding need for additional mounting feet
- Different baffle distances
- Stainless steel versions available
- IT integrated water tank solutions available

Investment with a favorable payback

The technical features presented above will interact to meet high COP in large-scale industrial, commercial and HVAC installations where cooling is needed during the major part of the year. In these cases, reduction of power consumption is an obvious success factor – and the Dryplus-E series is designed to offer the final user a favorable payback on the investment.

Refrigerant efficiency

Compared with other refrigerants used frequently, R134a offers excellent performance. In most applications, the difference can be demonstrated in plain figures. The Dryplus-E series offers the first evaporators designed specifically to maximize the benefits of using this highly effective refrigerant.



Alfa Laval in brief

Alfa Laval is a leading global provider of specialized products and engineered solutions.

Our equipment, systems and services are dedicated to helping customers to optimize the performance of their processes. Time and time again.

We help our customers to heat, cool, separate and transport products such as oil, water, chemicals, beverages, foodstuffs, starch and pharmaceuticals.

Our worldwide organization works closely with customers in almost 100 countries to help them stay ahead.

How to contact Alfa Laval

Up-to-date Alfa Laval contact details for all countries are always available on our website at www.alfalaval.com

